

LG

MULTI V 

Heat Pump/Cooling Only 380-415V + 380V
R410A(50Hz/60Hz)
0CVM0-03A(Replaces 0CVM0-02B)

TOTAL HVAC SOLUTION PROVIDER

ENGINEERING PRODUCT DATA BOOK





General Information

- 1. Model Names**
- 2. External Appearance**
- 3. Nomenclature**

1. Model Names

1.1 Heat Pump (ARUN)

Power Supply	4HP	5HP	6HP	8HP	10HP	12HP
1Ø, 220-240V, 50Hz 1Ø, 220V, 60Hz	040GSS0	050GSS0	060GSS0	-	-	-
3Ø, 380-415V, 50Hz 3Ø, 380V, 60Hz	040LSS0	050LSS0	060LSS0	080LSS0	100LSS0	120LSS0

1.2 Cooling Only (ARUV)

Power Supply	14HP
3Ø, 380-415V, 50Hz 3Ø, 380V, 60Hz	140LSS0

2. External Appearance

CHASSIS	Model Name	Model
U4	ARUN040GSS0	
U3	ARUN050GSS0 ARUN060GSS0 ARUN040LSS0 ARUN050LSS0 ARUN060LSS0 ARUN080LSS0	
U7	ARUN100LSS0 ARUN120LSS0 ARUV140LSS0	

3. Nomenclature

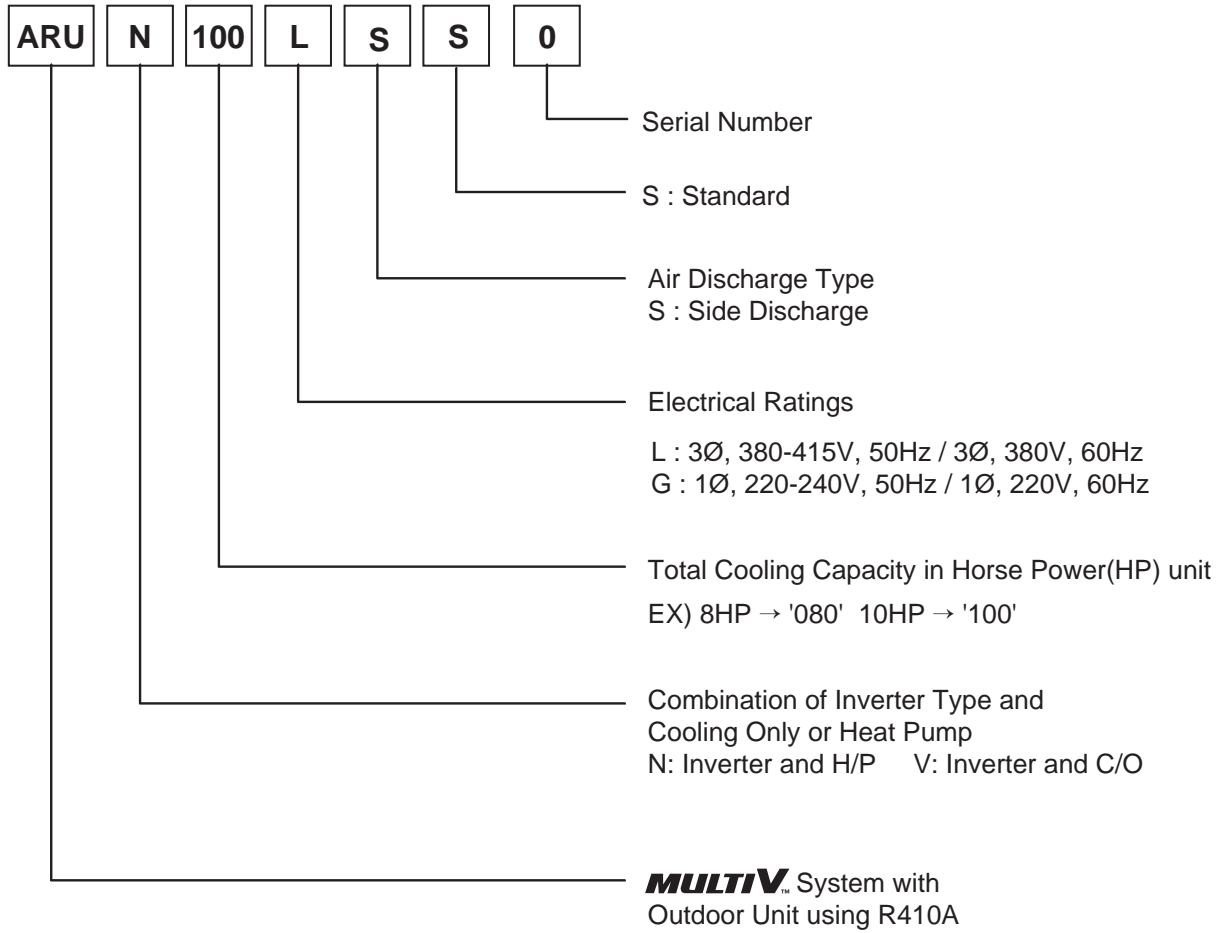



Outdoor Units

- 1. Outdoor Unit Function**
- 2. Specifications**
- 3. Dimensions**
- 4. Electric Characteristics**
- 5. Indoor Unit and Outdoor Unit Capacity Index**
- 6. Capacity Tables**
- 7. Capacity Correction Factor**
- 8. Operation Limits**
- 9. Piping Diagrams**
- 10. Wiring Diagrams**
- 11. Field Wiring**
- 12. Sound Levels**

1. Outdoor Unit Function

Category	Functions	Multi V S
Reliability	Defrost / Deicing	O
	High pressure switch	O
	Phase protection	O
	Restart delay (3-minutes)	O
	Self diagnosis	O
	Soft start	O
	Test Run function	O
Convenience	Night Silent Operation	O
CAC network function	Network solution(LGAP)	O

Note :

O : Applied, X : Not applied

Accessory model name : Installed at field, ordered and purchased separately by the corresponding model name, supplied with separate package.

Device		Multi V S
Central Controller	AC Ez (Simple Controller)	PQCSZ250S0
	AC Smart II	PQCSW320A1E
	AC Smart Premium	PQCSW421E0A
	128 Unit Expansion Kit for AC Smart	PQCSE440U0
	Option Kit (SD card type) for AC Smart	PQCSE341A0 / PQCSE342A0
	ACP(Advanced Control Platform)	PQCPA11A0E / PQCPB11A0E
	AC Manager	PQCSS520A0E
	ACP(Advanced Control Platform) Standard	PQCPC22N0
	ACP(Advanced Control Platform) Premium	PQCPC22A0
	AC Manager Plus	PQCSSA21E0
	DO(Digital Output) Kit	PQNFP00T0
BNU (Building Network Unit)	PI485	X
	LONWORKS Gateway (DC 12V Adapter)	PQNFB16A1 / PLNWKB000
	LONWORKS Gateway (AC 24 V)	X
	BACnet Gateway (DC 12V Adapter)	PQNFB17B0 / PQNFB17C0
Installation	BACnet Gateway (AC 24 V)	X
	Refrigerant Charging Kit	O (Logical operation)
	Variable Water Flow Control Kit	X
	PDI(power distribution indicator)	PQNUD1S00
	PDI(power distribution indicator) Premium	PQNUD1S40
	Cool / Heat Selector	PRDSBM
	ODU Dry Contact	PQDSBCDVM0
	IO Module (ODU Dry Contact)	PVDSMN000
	Low Ambient Kit	X
Cycle Monitoring Device	LG MV	PRCT-FE1
	Mobile LGMV(Bluetooth)	PMVBTDQ01
	DS(Data Saving) Module	PVADTN000
	Internet Bridge	PWFMD000

Note :

O : Applied, X : Not applied

Accessory model name : Installed at field, ordered and purchased separately by the corresponding model name, supplied with separate package.

2. Specifications

■ Heat Pump (1Ø)

50Hz/60Hz

HP			4	5	6
Model Name	Combination Unit		ARUN040GSS0	ARUN050GSS0	ARUN060GSS0
Capacity ¹⁾ (Rated)	Cooling	kW	12.1	14.0	15.5
		kcal/h	10,400	12,000	13,300
		Btu/h	41,200	47,800	52,900
	Heating	kW	12.5	16.0	18.0
		kcal/h	10,800	13,800	15,500
		Btu/h	42,700	54,600	61,400
Input (Rated) ¹⁾	Cooling	kW	2.95	3.38	3.96
	Heating	kW	2.91	3.52	4.09
Power Factor	Rated	-	0.93	0.93	0.93
Casing Color			Warm Gray	Warm Gray	Warm Gray
Heat Exchanger			Gold fin	Gold fin	Gold fin
Compressor	Type		Hermetic Motor Compressor	Hermetic Motor Compressor	Hermetic Motor Compressor
	Piston Displacement	cm ³ /rev	44.2	44.2	44.2
	Number of Revolution	rev/min	3,600	3,600	3,600
	Motor Output x Number	W x No.	4,000 x 1	4,000 x 1	4,000 x 1
	Starting Method		DC Inverter Starting	DC Inverter Starting	DC Inverter Starting
	Oil Type		FVC68D(PVE)	FVC68D(PVE)	FVC68D(PVE)
	Oil Charge		1,300	1,300	1,300
Fan	Type		Axial Flow Fan	Axial Flow Fan	Axial Flow Fan
	Motor Output x Number	W	124 x 1	124 x 2	124 x 2
	Air Flow Rate(High)	m ³ /min	60	110	110
		ft ³ /min	2,119	3,885	3,885
	Drive		DC INVERTER	DC INVERTER	DC INVERTER
Discharge		Side / Top	Side	Side	Side
Piping Connections	Liquid	mm(inch)	9.52(3/8)	9.52(3/8)	9.52(3/8)
	Gas	mm(inch)	15.88(5/8)	15.88(5/8)	19.05(3/4)
Dimensions(W x H x D)	mm		950 x834 x330	950 x1,380 x330	950 x1,380 x330
	mm		37-13/32 x 32-27/32 x 13	37-13/32 x 54-11/32 x 13	37-13/32 x 54-11/32 x 13
Net Weight	kg		69	94	94
	lbs		152	207	207
Sound Pressure Level	Cooling	dB(A)	50	51	52
	Heating	dB(A)	52	53	54
Sound Power Level	dB(A)		62	66	67
Protection Devices	High pressure protection	-	High pressure sensor / High pressure switch	High pressure sensor / High pressure switch	High pressure sensor / High pressure switch
	Compressor/ Fan	-	Over-heat protection / Fan driver overload protector	Over-heat protection / Fan driver overload protector	Over-heat protection / Fan driver overload protector
	Inverter	-	Over-heat protection / Over-current protection	Over-heat protection / Over-current protection	Over-heat protection / Over-current protection
Communication Cable	No.xmm ² (VCTF-SB)		2C x 1.0 ~ 1.5	2C x 1.0 ~ 1.5	2C x 1.0 ~ 1.5
Refrigerant	Refrigerant name		R410A	R410A	R410A
	Precharged Amount	kg	1.8	3.0	3.0
		lbs	4.0	6.6	6.6
	Control		Electronic Expansion Valve	Electronic Expansion Valve	Electronic Expansion Valve
Power Supply	V, Ø, Hz		220-240 , 1 , 50	220-240 , 1 , 50	220-240 , 1 , 50
			220, 1, 60	220, 1, 60	220, 1, 60
Number of maximum connectable indoor units ²⁾			6	8	9

Notes:

- Capacities are based on the following conditions:
 - Cooling Temperature : Indoor 27°C(80.6°F) DB / 19°C(66.2°F) WB
Outdoor 35°C(95°F) DB / 24°C(75.2°F) WB
 - Heating Temperature : Indoor 20°C(68°F) DB / 15°C(59°F) WB
Outdoor 7°C(44.6°F) DB / 6°C(42.8°F) WB
 - Piping Length : Interconnected Pipe Length = 7.5m
 - Difference Limit of Elevation (Outdoor ~ Indoor Unit) is Zero.
- The maximum combination ratio is 160%.
- Wiring cable size must comply with the applicable local and national codes.
- Due to our policy of innovation some specifications may be changed without notification.
- Sound Level Values are measured at Anechoic chamber. Therefore, these values can be increased owing to ambient conditions during operation.
- Power factor could vary less than ±1% according to the operating conditions.

2. Specifications

■ Heat Pump (3Ø)

50Hz/60Hz

HP			4	5	6
Model Name	Combination Unit		ARUN040LSS0	ARUN050LSS0	ARUN060LSS0
Capacity ¹⁾ (Rated)	Cooling	kW	12.1	14.0	15.5
		kcal/h	10,400	12,000	13,300
		Btu/h	41,200	47,800	52,900
	Heating	kW	12.5	16.0	18.0
		kcal/h	10,800	13,800	15,500
		Btu/h	42,700	54,600	61,400
Input (Rated) ¹⁾	Cooling	kW	2.80	3.38	3.96
	Heating	kW	2.75	3.52	4.09
Power Factor	Rated	-	0.93	0.93	0.93
Casing Color			Warm Gray	Warm Gray	Warm Gray
Heat Exchanger			Gold fin	Gold fin	Gold fin
Compressor	Type		Hermetic Motor Compressor	Hermetic Motor Compressor	Hermetic Motor Compressor
	Piston Displacement	cm ³ /rev	44.2	44.2	44.2
	Number of Revolution	rev/min	3,600	3,600	3,600
	Motor Output x Number	W x No.	4,000 x 1	4,000 x 1	4,000 x 1
	Starting Method		DC Inverter Starting	DC Inverter Starting	DC Inverter Starting
	Oil Type		FVC68D(PVE)	FVC68D(PVE)	FVC68D(PVE)
	Oil Charge		1,300	1,300	1,300
Fan	Type		Axial Flow Fan	Axial Flow Fan	Axial Flow Fan
	Motor Output x Number	W	124 x 2	124 x 2	124 x 2
	Air Flow Rate(High)	m ³ /min	110	110	110
		ft ³ /min	3,885	3,885	3,885
	Drive		DC INVERTER	DC INVERTER	DC INVERTER
Discharge	Side / Top	Side	Side	Side	
Piping Connections	Liquid	mm(inch)	9.52(3/8)	9.52(3/8)	9.52(3/8)
	Gas	mm(inch)	15.88(5/8)	15.88(5/8)	19.05(3/4)
Dimensions(W x H x D)	mm		950 x 1,380 x 330	950 x 1,380 x 330	950 x 1,380 x 330
	mm		37-13/32 x 54-11/32 x 13	37-13/32 x 54-11/32 x 13	37-13/32 x 54-11/32 x 13
Net Weight	kg		96	96	96
	lbs		212	212	212
Sound Pressure Level	Cooling	dB(A)	50	51	52
	Heating	dB(A)	52	53	54
Sound Power Level	dB(A)		63	66	67
Protection Devices	High pressure protection	-	High pressure sensor / High pressure switch	High pressure sensor / High pressure switch	High pressure sensor / High pressure switch
	Compressor/ Fan	-	Over-heat protection / Fan driver overload protector	Over-heat protection / Fan driver overload protector	Over-heat protection / Fan driver overload protector
	Inverter	-	Over-heat protection / Over-current protection	Over-heat protection / Over-current protection	Over-heat protection / Over-current protection
Communication Cable	No.xmm ² (VCTF-SB)		2C x 1.0 ~ 1.5	2C x 1.0 ~ 1.5	2C x 1.0 ~ 1.5
Refrigerant	Refrigerant name		R410A	R410A	R410A
	Precharged Amount	kg	3.0	3.0	3.0
		lbs	6.6	6.6	6.6
	Control		Electronic Expansion Valve	Electronic Expansion Valve	Electronic Expansion Valve
Power Supply	V, Ø, Hz		380-415, 3, 50	380-415, 3, 50	380-415, 3, 50
	V, Ø, Hz		380, 3, 60	380, 3, 60	380, 3, 60
Number of maximum connectable indoor units ²⁾			6	8	9

Notes:

- Capacities are based on the following conditions:
 - Cooling Temperature : Indoor 27°C(80.6°F) DB / 19°C(66.2°F) WB
Outdoor 35°C(95°F) DB / 24°C(75.2°F) WB
 - Heating Temperature : Indoor 20°C(68°F) DB / 15°C(59°F) WB
Outdoor 7°C(44.6°F) DB / 6°C(42.8°F) WB
 - Piping Length : Interconnected Pipe Length = 7.5m
 - Difference Limit of Elevation (Outdoor ~ Indoor Unit) is Zero.
- The maximum combination ratio is 160%.
- Wiring cable size must comply with the applicable local and national codes.
- Due to our policy of innovation some specifications may be changed without notification.
- Sound Level Values are measured at Anechoic chamber. Therefore, these values can be increased owing to ambient conditions during operation.
- Power factor could vary less than ±1% according to the operating conditions.

Outdoor Units

2. Specifications

50Hz/60Hz

HP			8	10	12
Model Name	Combination Unit		ARUN080LSS0	ARUN100LSS0	ARUN120LSS0
Capacity ¹⁾ (Rated)	Cooling	kW	22.4	28.0	33.6
		kcal/h	19,300	24,100	28,900
		Btu/h	76,400	95,900	114,700
	Heating	kW	25.2	31.5	37.8
		kcal/h	21,700	27,100	32,500
		Btu/h	86,000	107,500	129,000
Input (Rated) ¹⁾	Cooling	kW	5.89	7.09	9.08
	Heating	kW	6.00	7.41	9.95
Power Factor	Rated	-	0.93	0.93	0.93
Casing Color			Warm Gray	Warm Gray	Warm Gray
Heat Exchanger			Gold fin	Gold fin	Gold fin
Compressor	Type		Hermetically Sealed Scroll	Hermetically Sealed Scroll	Hermetically Sealed Scroll
	Piston Displacement	cm ³ /rev	43.8	62.1	62.1
	Number of Revolution	rev/min	3,600	3,600	3,600
	Motor Output x Number	W x No.	4,200 x 1	5,300 x 1	5,300 x 1
	Starting Method		Direct On Line	Direct On Line	Direct On Line
	Oil Type		FVC68D(PVE)	FVC68D(PVE)	FVC68D(PVE)
	Oil Charge		2,400	2,600	3,400
Fan	Type		Propeller fan	Propeller fan	Propeller fan
	Motor Output x Number	W	124 x 2	250 x 2	250 x 2
	Air Flow Rate(High)	m ³ /min	140	190	190
		ft ³ /min	4,944	6,710	6,710
	Drive		DC INVERTER	DC INVERTER	DC INVERTER
Discharge		Side / Top	Side	Side	
Piping Connections	Liquid	mm(inch)	9.52(3/8)	9.52(3/8)	12.7(1/2)
	Gas	mm(inch)	19.05(3/4)	22.2(7/8)	28.58(1 1/8)
Dimensions(W x H x D)	mm		950 x 1,380 x 330	1,090 x 1,625 x 380	1,090 x 1,625 x 380
	mm		37-13/32 x 54-11/32 x 13	42-29/32 x 63-31/32 x 14-31/32	42.9 x 64.0 x 15.0
Net Weight	kg		115	144	157
	lbs		254	317	346
Sound Pressure Level	Cooling	dB(A)	57	58	60
	Heating	dB(A)	57	58	60
Sound Power Level			69	70	71
Protection Devices	High pressure protection	-	High pressure sensor / High pressure switch	High pressure sensor / High pressure switch	High pressure sensor / High pressure switch
	Compressor/ Fan	-	Over-heat protection / Fan driver overload protector	Over-heat protection / Fan driver overload protector	Over-heat protection / Fan driver overload protector
	Inverter	-	Over-heat protection / Over-current protection	Over-heat protection / Over-current protection	Over-heat protection / Over-current protection
Communication Cable	No.xmm ² (VCTF-SB)		2C x 1.0 ~ 1.5	2C x 1.0 ~ 1.5	2C x 1.0 ~ 1.5
Refrigerant	Refrigerant name		R410A	R410A	R410A
	Precharged Amount	kg	3.5	4.5	6.0
		lbs	7.7	9.9	13.2
	Control		Electronic Expansion Valve	Electronic Expansion Valve	Electronic Expansion Valve
Power Supply	V, Ø, Hz		380-415, 3, 50	380-415, 3, 50	380-415, 3, 50
			380, 3, 60	380, 3, 60	380, 3, 60
Number of maximum connectable indoor units ²⁾			13	16	20

Notes:

- Capacities are based on the following conditions:
 - Cooling Temperature : Indoor 27°C(80.6°F) DB / 19°C(66.2°F) WB
Outdoor 35°C(95°F) DB / 24°C(75.2°F) WB
 - Heating Temperature : Indoor 20°C(68°F) DB / 15°C(59°F) WB
Outdoor 7°C(44.6°F) DB / 6°C(42.8°F) WB
 - Piping Length : Interconnected Pipe Length = 7.5m
 - Difference Limit of Elevation (Outdoor ~ Indoor Unit) is Zero.
- The maximum combination ratio is 160%.
- Wiring cable size must comply with the applicable local and national codes.
- Due to our policy of innovation some specifications may be changed without notification.
- Sound Level Values are measured at Anechoic chamber. Therefore, these values can be increased owing to ambient conditions during operation.
- Power factor could vary less than ±1% according to the operating conditions.

2. Specifications

■ Cooling Only (3Ø)

50Hz/60Hz

HP			14
Model Name	Combination Unit		ARUV140LSS0
Capacity ¹⁾ (Rated)	Cooling	kW	38.0
		kcal/h	32,700
		Btu/h	129,700
	Heating	kW	-
		kcal/h	-
		Btu/h	-
Input (Rated) ¹⁾	Cooling	kW	11.88
	Heating	kW	-
Power Factor	Rated	-	0.93
Casing Color			Warm Gray
Heat Exchanger			Gold fin
Compressor	Type		Hermetically Sealed Scroll
	Piston Displacement	cm ³ /rev	62.1
	Number of Revolution	rev/min	3,600
	Motor Output x Number	W x No.	5,300 x 1
	Starting Method		Direct On Line
	Oil Type		FVC68D(PVE)
	Oil Charge		3,400
Fan	Type		Propeller fan
	Motor Output x Number	W	250 x 2
	Air Flow Rate(High)	m ³ /min	190
		ft ³ /min	6,710
	Drive		DC INVERTER
Discharge		Side / Top	
Piping Connections	Liquid	mm(inch)	12.7(1/2)
	Gas	mm(inch)	28.58(1-1/8)
Dimensions(W x H x D)		mm	1,090 x 1,625 x 380
		mm	42-29/32 x 63-31/32 x 14-31/32
Net Weight		kg	157
		lbs	346
Sound Pressure Level	Cooling	dB(A)	63
	Heating	dB(A)	-
Sound Power Level		dB(A)	74
Protection Devices	High pressure protection	-	High pressure sensor / High pressure switch
	Compressor/ Fan	-	Over-heat protection / Fan driver overload protector
	Inverter	-	Over-heat protection / Over-current protection
Communication Cable	No.xmm ² (VCTF-SB)		2C x 1.0 ~ 1.5
Refrigerant	Refrigerant name		R410A
	Precharged Amount	kg	6.0
		lbs	13.2
	Control		Electronic Expansion Valve
Power Supply		V, Ø, Hz	380-415 , 3 , 50
			380 , 3 , 60
Number of maximum connectable indoor units ²⁾			23

Notes:

- Capacities are based on the following conditions:
 - Cooling Temperature : Indoor 27°C(80.6°F) DB / 19°C(66.2°F) WB
Outdoor 35°C(95°F) DB / 24°C(75.2°F) WB
 - Heating Temperature : Indoor 20°C(68°F) DB / 15°C(59°F) WB
Outdoor 7°C(44.6°F) DB / 6°C(42.8°F) WB
 - Piping Length : Interconnected Pipe Length = 7.5m
 - Difference Limit of Elevation (Outdoor ~ Indoor Unit) is Zero.

- The maximum combination ratio is 160%.
- Wiring cable size must comply with the applicable local and national codes.
- Due to our policy of innovation some specifications may be changed without notification.
- Sound Level Values are measured at Anechoic chamber. Therefore, these values can be increased owing to ambient conditions during operation.
- Power factor could vary less than ±1% according to the operating conditions.

MULTI V™ S

3. Dimensions

3.1 Dimensional Drawings

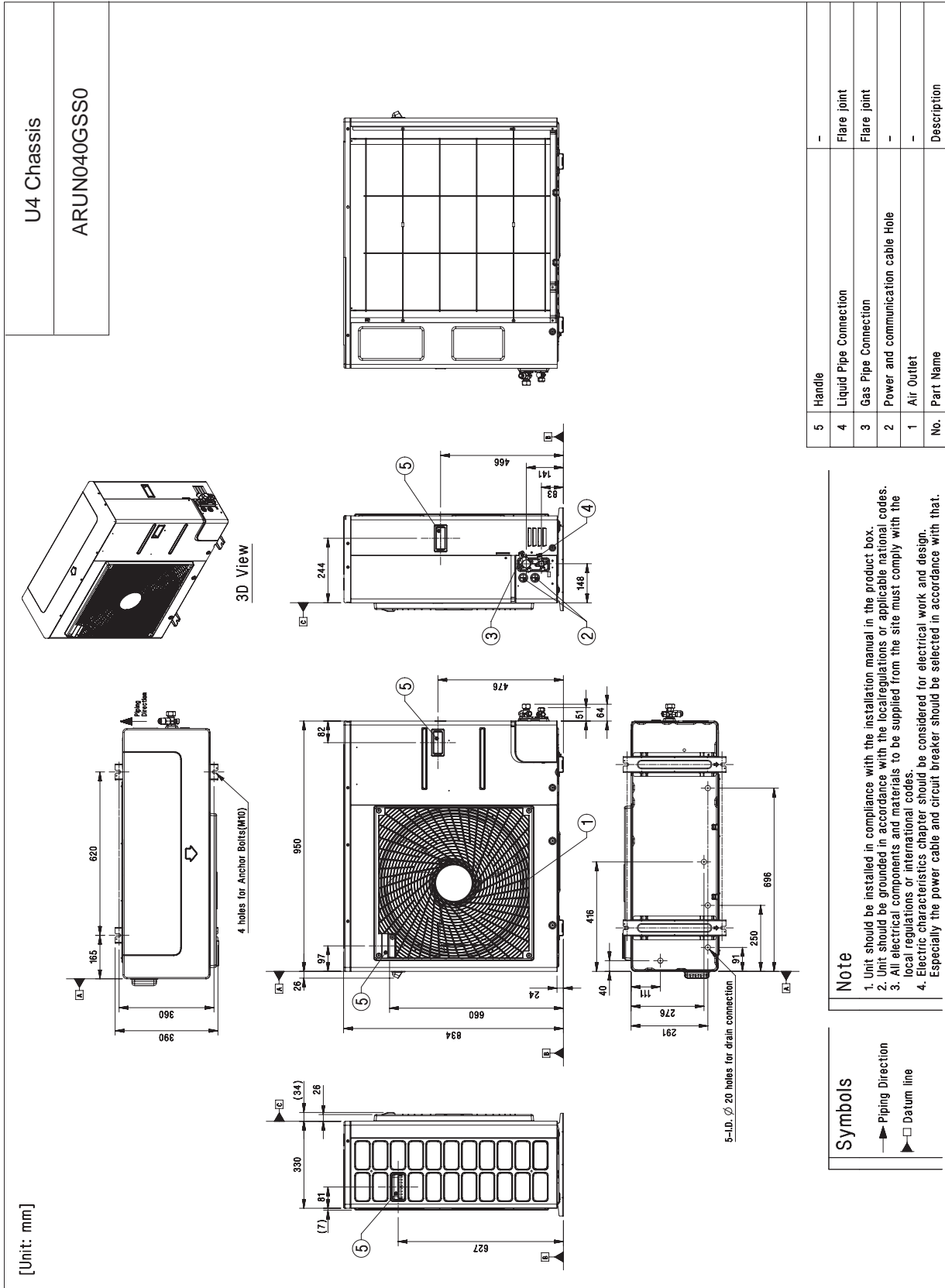

3. Dimensions

[Unit: mm]

4 holes for Anchor Bolts (M10)

3D View

U3 Chassis

ARUN050GSS0
ARUN060GSS0
ARUN040LSS0
ARUN050LSS0
ARUN060LSS0
ARUN080LSS0

Piping connection port

5-ID, ∅20 holes for drain connection

Note

- Unit should be installed in compliance with the installation manual in the product box.
- Unit should be grounded in accordance with the local regulations or applicable national codes.
- All electrical components and materials to be supplied from the site must comply with the local regulations or international codes.
- Electrical characteristics chapter should be considered for electrical work and design. Especially the power cable and circuit breaker should be selected in accordance with that.

Symbols

- Piping Direction
- ▲ Datum line

No.	Part Name	Description
8	Pipe routing hole (back)	-
7	Pipe routing hole (side)	-
6	Pipe routing hole (front)	-
5	Handle	-
4	Liquid Pipe Connection	Welding joint
3	Gas Pipe Connection	Welding joint
2	Power and communication cable Hole	-
1	Air Outlet	-

MULTI V™ S

3. Dimensions

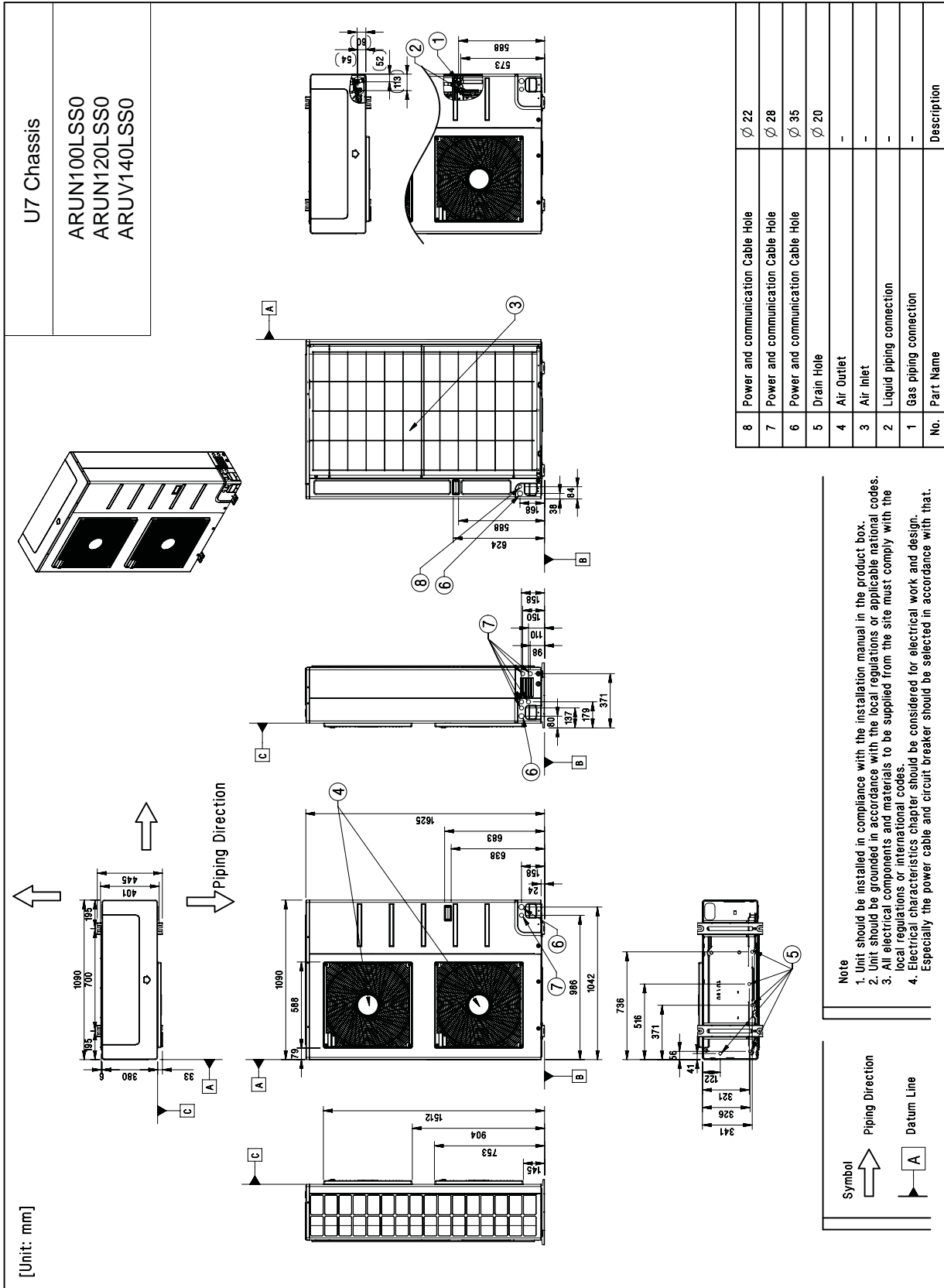

3. Dimensions

3.2 Center of Gravity

ARUN040GSS0 [Unit : mm]

Model Name	X	Y	Z
ARUN040GSS0	740	340	170

ARUN050GSS0
ARUN060GSS0
ARUN040LSS0
ARUN050LSS0
ARUN060LSS0
ARUN080LSS0
[Unit : mm]

Model Name	X	Y	Z
ARUN050GSS0	440	657	233
ARUN060GSS0			
ARUN040LSS0			
ARUN050LSS0			
ARUN060LSS0			
ARUN080LSS0			

3. Dimensions

ARUN100LSS0
ARUN120LSS0
ARUV140LSS0

[Unit : mm]

Model Name	X	Y	Z
ARUN100LSS0			
ARUN120LSS0	522	750	256
ARUV140LSS0			

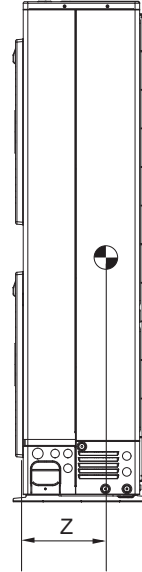
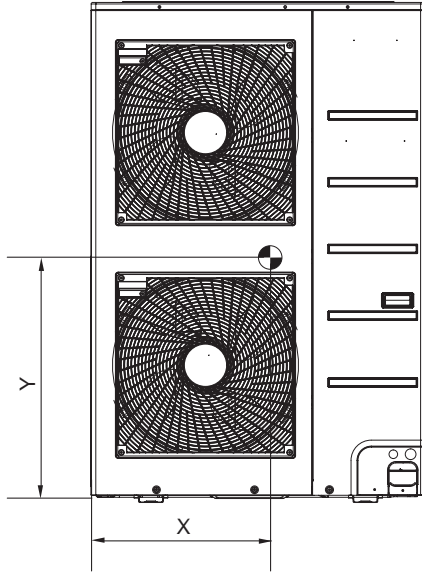

4. Electric Characteristics

◆ Wiring of Main Power Supply and Equipment Capacity

1. Use a separate power supply for the Outdoor Unit and Indoor Unit.
2. Bear in mind ambient conditions (ambient temperature, direct sunlight, rain liquid, etc.) when proceeding with the wiring and connections.
3. The wire size is the minimum value for metal conduit wiring. The power cord size should be 1 rank thicker taking into account the line voltage drops. Make sure the power-supply voltage does not drop more than 10%.
4. Specific wiring requirements should adhere to the wiring regulations of the region.
5. Power supply cords of parts of appliances for outdoor use should not be lighter than polychloroprene sheathed flexible cord.
6. Don't install an individual switch or electrical outlet to disconnect each of indoor unit separately from the power supply.

⚠ WARNING

- Follow ordinance of your governmental organization for technical standard related to electrical equipment, wiring regulations and guidance of each electric power company.
- Make sure to use specified wires for connections so that no external force is imparted to terminal connections. If connections are not fixed firmly, it may cause heating or fire.
- Make sure to use the appropriate type of overcurrent protection switch. Note that generated overcurrent may include some amount of direct current.

⚠ CAUTION

- Some installation site may require attachment of an earth leakage breaker. If no earth leakage breaker is installed, it may cause an electric shock.
- Do not use anything other than breaker and fuse with correct capacity. Using fuse and wire or copper wire with too large capacity may cause a malfunction of unit or fire.

4. Electric Characteristics

4.1 Heat Pump (1Ø)

◆ 50Hz

Model	Unit			Power Supply			COMP			OFM	
	Hz	Volts	Voltage-range	MCA	TOCA	MFA	MSC	RLA(Cooling)	RLA(Heating)	kW	FLA
4 HP	50	220-240	Min.:198, Max.:264	25.0	26.0	30	-	12.9	13.7	0.12	1.0
5 HP	50	220-240	Min.:198, Max.:264	27.5	26.0	30	-	16.1	17.2	0.35	1.0
6 HP	50	220-240	Min.:198, Max.:264	29.4	26.0	40	-	18.8	20.5	0.35	1.0

◆ 60Hz

Model	Unit			Power Supply			COMP			OFM	
	Hz	Volts	Voltage-range	MCA	TOCA	MFA	MSC	RLA(Cooling)	RLA(Heating)	kW	FLA
4 HP	60	220	Min.:198, Max.:242	25.0	26.0	30	-	12.9	13.7	0.12	1.0
5 HP	60	220	Min.:198, Max.:242	27.5	26.0	30	-	16.1	17.2	0.35	1.0
6 HP	60	220	Min.:198, Max.:242	29.4	26.0	40	-	18.8	20.5	0.35	1.0

4.2 Heat Pump (3Ø)

◆ 50Hz

Model	Unit			Power Supply			COMP			OFM	
	Hz	Volts	Voltage-range	MCA	TOCA	MFA	MSC	RLA(Cooling)	RLA(Heating)	kW	FLA
4 HP	50	380-415	Min.:342, Max.:456	10.9	14.0	20	-	3.2	3.7	0.35	1.0
5 HP	50	380-415	Min.:342, Max.:456	12.5	14.0	20	-	4.6	5.4	0.35	1.0
6 HP	50	380-415	Min.:342, Max.:456	14.0	14.0	20	-	5.8	6.2	0.35	1.0
8 HP	50	380-415	Min.:342, Max.:456	21.3	24.0	30	4.0	8.4	8.6	0.35	1.0
10 HP	50	380-415	Min.:342, Max.:456	26.3	35.0	30	4.5	9.3	9.5	0.50	2.8
12 HP	50	380-415	Min.:342, Max.:456	32.5	35.0	35	4.5	12.0	13.5	0.50	2.8

◆ 60Hz

Model	Unit			Power Supply			COMP			OFM	
	Hz	Volts	Voltage-range	MCA	TOCA	MFA	MSC	RLA(Cooling)	RLA(Heating)	kW	FLA
4 HP	60	380	Min.:342, Max.:418	10.9	14.0	20	-	3.2	3.7	0.35	1.0
5 HP	60	380	Min.:342, Max.:418	12.5	14.0	20	-	4.6	5.4	0.35	1.0
6 HP	60	380	Min.:342, Max.:418	14.0	14.0	20	-	5.8	6.2	0.35	1.0
8 HP	60	380	Min.:342, Max.:418	21.3	24.0	30	4.0	8.4	8.6	0.35	1.0
10 HP	60	380	Min.:342, Max.:418	26.3	35.0	30	4.5	9.3	9.5	0.50	2.8
12 HP	60	380	Min.:342, Max.:418	32.5	35.0	35	4.5	12.0	13.5	0.50	2.8

Notes:

1. Voltage range
Voltage supplied to the unit terminals should be within the minimum and maximum range
2. Maximum allowable voltage unbalance between phase is 2%
3. OFM is measured as the outdoor unit test condition.
4. Select wire spec. based on the larger value of MCA or TOCA.
5. TOCA means the total over current value of each outdoor unit.
6. MSC means the Max. current during the starting of compressor.
7. Recommended circuit breaker is ELCB (Earth Leakage Circuit Breaker)

8. MFA is used to select the circuit breaker and ground fault circuit interrupter (earth leakage circuit breaker)

MCA : Minimum Circuit Amperes (A) MSC : Maximum Starting Current RLA : Rated Load Amperes (A) OFM : Outdoor Fan Motor kW : Fan Motor rated output (kW) FLA : Full Load Amperes (A) MFA: Maximum Fuse Amperes(A) TOCA: Total Over Current Amperes(A)
--

4. Electric Characteristics

4.3 Cooling Only (3Ø)

◆ 50Hz

Model	Unit			Power Supply			COMP			OFM	
	Hz	Volts	Voltage-range	MCA	TOCA	MFA	MSC	RLA(Cooling)	RLA(Heating)	kW	FLA
14 HP	50	380-415	Min.:342, Max.:456	26.3	30.0	30	4.5	12.2	-	0.50	2.8

◆ 60Hz

Model	Unit			Power Supply			COMP			OFM	
	Hz	Volts	Voltage-range	MCA	TOCA	MFA	MSC	RLA(Cooling)	RLA(Heating)	kW	FLA
14 HP	60	380	Min.:342, Max.:418	26.3	30.0	30	4.5	12.2	-	0.50	2.8

Notes:

1. Voltage range
Voltage supplied to the unit terminals should be within the minimum and maximum range
2. Maximum allowable voltage unbalance between phase is 2%
3. OFM is measured as the outdoor unit test condition.
4. Select wire spec. based on the larger value of MCA or TOCA.
5. TOCA means the total over current value of each outdoor unit.
6. MSC means the Max. current during the starting of compressor.
7. Recommended circuit breaker is ELCB (Earth Leakage Circuit Breaker)
8. MFA is used to select the circuit breaker and ground fault circuit interrupter (earth leakage circuit breaker)

MCA : Minimum Circuit Amperes (A) MSC : Maximum Starting Current RLA : Rated Load Amperes (A) OFM : Outdoor Fan Motor kW : Fan Motor rated output (kW) FLA : Full Load Amperes (A) MFA: Maximum Fuse Amperes(A) TOCA: Total Over Current Amperes(A)
--

5. Indoor Unit and Outdoor Unit Capacity Index

5.1 Outdoor Unit Selection

See the indoor unit capacity tables for given Indoor and Outdoor temperature.
Select the unit whose capacity is the nearest to or greater than given load.

Note:

Individual Indoor Unit capacity is subject to change by combination. Actual capacity has to be calculated according to the combination by using Outdoor unit capacity table.

5.2 Outdoor Unit Selection

Allowable combinations are indicated below. In general, outdoor unit can be selected depending on the location of the unit, zoning and usage of the rooms.

The indoor and outdoor unit combination is determined by comparing the sum of indoor unit capacity index with each Outdoor Unit. It is recommended to be the nearest to 100% combination ratio or to be smaller than that. Refer the table below. To manage cooling/heating load properly, it's better to be selected the bigger capacity outdoor unit rather than the nearest, if the installation space is large enough.

Allowable Total Capacity Index Table of Combined Indoor Units

Outdoor Unit Capacity(HP)	Indoor Unit Combination Ratio								
	50%	60%	70%	80%	90%	100%	110%	120%	130%
4	6.1	7.3	8.5	9.7	10.9	12.1	13.3	14.5	15.7
5	7.0	8.4	9.8	11.2	12.6	14.0	15.4	16.8	18.2
6	7.8	9.3	10.9	12.4	14.0	15.5	17.1	18.6	20.2
8	11.2	13.4	15.7	17.9	20.2	22.4	24.6	26.9	29.1
10	14.0	16.8	19.6	22.4	25.2	28.0	30.8	33.6	36.4
12	16.8	20.2	23.5	26.9	30.2	33.6	37.0	40.3	43.7
14	19.0	22.8	26.6	30.4	34.2	38.0	41.8	45.6	49.4

* Capacity Index is same as the capacity(kW).

INDOOR UNIT CAPACITY INDEX

Unit Capacity (Btu/h)	5k	7k	9k	12k	15k	18k	21k	24k	28k	36k	42k	48k	54k	76k	96k
Capacity Index	1.6	2.2	2.8	3.6	4.5	5.6	6.2	7.1	8.2	10.6	12.3	14.1	15.8	22.4	28.0

* Capacity Index is same as the capacity(kW).

⚠ CAUTION

■ Combination Ratio(50~160%)

Notes :

- 1) We can guarantee the operation only within 130% combination ratio.
If you want to connect more than 130% combination ratio, please contact us and discuss the requirement.
- 2) In case that operating indoor units ratio to rated capacity of outdoor unit is more than 130%, the airflow should be operated as low step in the all indoor units.
- 3) This combination ratio is applied only for outdoor units which are produced after Jan. 1st, 2015.